



Reg. No. :

--	--	--	--	--	--	--	--	--	--	--	--	--	--	--

Question Paper Code : 91848

B.E./B.Tech. DEGREE EXAMINATIONS, NOVEMBER/DECEMBER 2019

Sixth/Seventh Semester

Mechanical Engineering

ME 6601 – DESIGN OF TRANSMISSION SYSTEMS

**(Common to Mechanical Engineering (Sandwich)/Mechanical and
Automation Engineering)**

(Regulations 2013)

**(Also Common to PTME 6601 – Design of Transmission Systems for B.E.
(Part-Time) – Fifth Semester – Mechanical Engineering – Regulations 2014)**

Time : Three Hours

Maximum : 100 Marks

Use of Design Data book is permitted.

Answer ALL questions.

PART – A

(10×2=20 Marks)

1. What do you mean by crowning of pulleys ?
2. State the advantages of chain drives.
3. What are the advantages of toothed gears over the other types of transmission systems ?
4. Why do you prefer helical gears than spur gears ?
5. Differentiate a straight bevel gear and a spiral bevel gear.
6. For transmitting large power, worm reductions gears are not generally preferred. Why ?
7. What does the ray diagram of gear box indicate ?
8. Specify four types of gear boxes.
9. Define base circle and pitch circle with respect to cam.
10. Why are cone clutches better than disc clutches ?



PART – B

(5×13=65 Marks)

11. a) Design a V-belt drive to run a centrifugal pump at 340 rpm is to be driven by a 100 kW motor running at 1440 rpm. The drive is to work for atleast 20 hours per day. The centre distance between the motor shaft and the pump shaft is 1200 mm. (13)
- (OR)
- b) Select a wire rope for a vertical mine hoist to lift a load of 20 kN from a depth of 500 metres. A rope speed of 3 m/s is to be attained in 10 seconds. (13)
12. a) Design a spur gear drive to transmit a power of 8 kW. Pinion speed is 764 rpm. Speed ratio is 2. The gears are to be made of C45. Life is to be 10,000 hours. (13)
- (OR)
- b) A pair of helical gears subjected to moderate shock loading is to transmit 37.5 kW at 1750 rpm of the pinion. The speed reduction ratio is 4.25 and the helix angle is 15° . The service is continuous and the teeth are 20° full depth in the normal plane. Design the gears, assuming a life of 10,000 hours. (13)
13. a) Design a bevel gear drive to transmit 7 kW at 1600 rpm for the following data. Gear ratio = 3, Material for pinion and gear = C45 Steel, Life = 10,000 hours. (13)
- (OR)
- b) The input to worm gear shaft is 18 kW and 600 rpm. Speed of worm wheel is 30 rpm. The worm is to be hardened steel and the wheel is made of chilled phosphor bronze. Considering wear and strength, design worm and worm wheel. (13)
14. a) Design the layout of a 12 speed gear box for a lathe. The minimum and maximum speeds are around to be 30 rpm and 1400 rpm respectively. Construct the speed diagram using a standard speed ratio and sketch the arrangement of the gear box. (13)
- (OR)
- b) Design a 16 speed gear box, the minimum speed is 100 rpm and maximum speed is 560 rpm. Construct the speed diagram using a standard speed ratio and sketch the arrangement of the gear box. (13)
15. a) A single plate clutch, effective on both sides, is required to transmit 25 kW at 1500 rpm. Determine the inner and outer diameter of friction surface if the coefficient of friction is 0.25, ratio of diameter is 1.5 and the maximum pressure is not to exceed 2 N/mm^2 . Also, determine the axial thrust to be provided by springs. Assume the theory of uniform wear and max. pressure theory. (13)
- (OR)



- b) A double shoe brake as shown in fig 15 (b) is capable of absorbing a torque of 1500 N-m. The diameter of the brake drum is 400 mm and the angle of contact for each shoe is 100° . If the coefficient of friction between the brake drum and lining is 0.4, find (i) the spring force necessary to set the brake and (ii) the width of the brake shoe, if the bearing pressure on the lining material is not to exceed 0.3 N/mm^2 . (13)

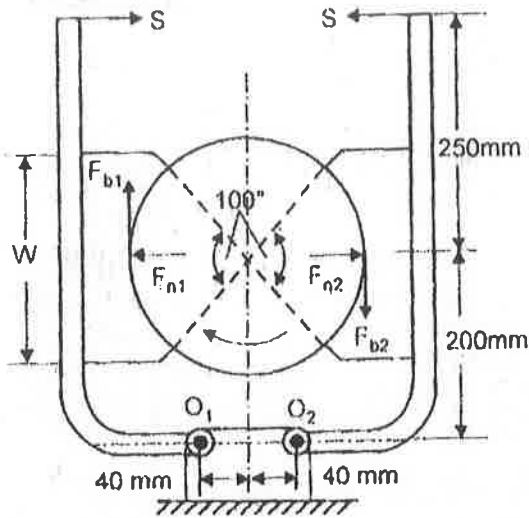

Fig 15 (b)

PART – C

(1×15=15 Marks)

16. a) i) State the condition and approaches to be followed to avoid under cutting in cam. (8)
ii) Discuss the force analysis and derive equation to determine the torque transmitted by it. (7)

(OR)

- b) i) Design a chain drive to actuate a compressor from a 10 kW electric motor at 960 rpm. The compressor speed is to be 350 rpm. Minimum centre distance should be 0.5 m. Motor is mounted on an auxiliary bed. Compressor is to work for 8 hours per day. (7)
ii) Variable speed drive is to be design to vary speed from 300 rpm to 600 rpm. Suggest a variable speed drive system and explain its kinematic arrangement. (8)

